

THE
CCCVA **NEWSLETTER**

THE JOURNAL OF THE CITROËN CAR CLUB OF VICTORIA Inc.

Internet: www.citcarclubvic.org.au

June 2023

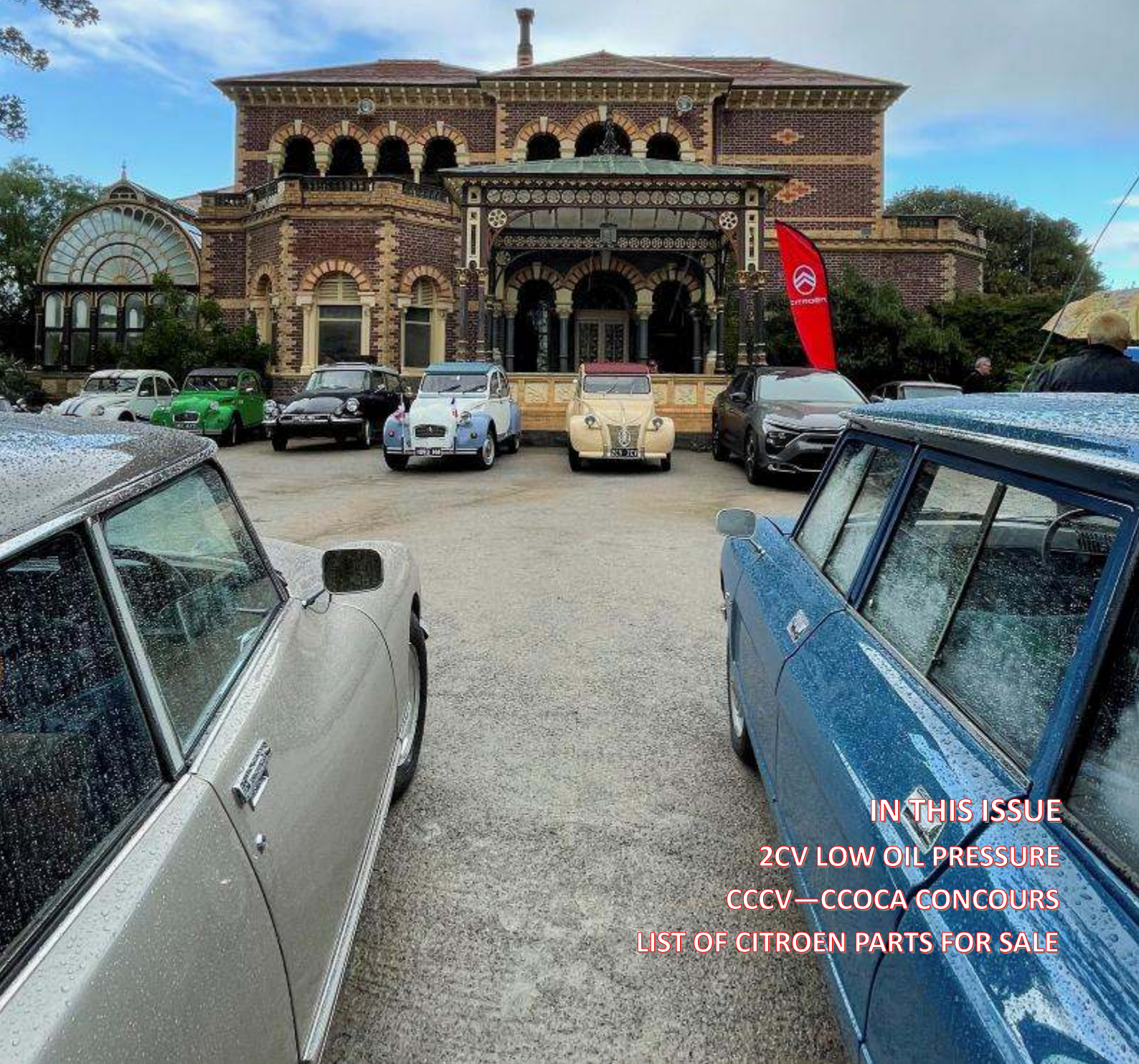

IN THIS ISSUE
2CV LOW OIL PRESSURE
CCCV—CCOCA CONCOURS
LIST OF CITROËN PARTS FOR SALE

CITROËN CAR CLUB OF VICTORIA Inc.

PO Box 122 Nunawading Vic 3131

PRESIDENT

Michael Faulks 0432 537 060 president@citcarclubvic.org.au

VICE PRESIDENT

SECRETARY

Ian Downey 0452 411 104 secretary @citcarclubvic.org.au

TREASURER

Peter Moloney 0411 869 705 treasurer@citcarclubvic.org.au

COMMITTEE

Editor Brian James 0427 534 014 photoimage2001@yahoo.com.au
Events Dave Rogers 0422 229 484 drogers11@gmail.com
C/shop Wolfgang Siem 0425 872 082 woljen@gmail.com
Haydn Kely 0432 252 229 haydnkely@gmail.com
John Parsons 0407 045 388

CLUB PERMIT SCHEME SECRETARIES

Dear Park Ferdi Saliba * 0409 384 977 ferdi.saliba@gmail.com
Nunawading Tom Gruzca * 0431 396 277
Frankston Dave Rogers * 0422 229 484
Endeavor Hills Bruno Tonizzo * 0418 945 461
Ashburton Peter Moloney * 0411 869 705

MEMBERSHIP SECRETARY

John Wyers M: 0423 930 999
membership@citcarclubvic.org.au

NEWSLETTER EDITOR

Brian James 0427 534 014
Photoimage2001@yahoo.com.au

EVENTS

Dave Rogers 0422 229 484

LIBRARIAN

John Parsons 0407 045 388

WEBSITE ADMINISTRATOR

Nick Hutton 0412 051 358

MEMBERSHIP RATE

Metropolitan including printed newsletter \$ 70.00
Country including printed newsletter \$ 55.00
Electronic only newsletter for above \$ 50.00 / \$ 35.00
For 2nd & subsequent members \$ 15.00

CCCV GENERAL MEETINGS

Club nights are held bi-monthly in our club rooms at 8/41 Norcal Road Nunawading, ON THE THIRD THURSDAY IN THE MONTH, starting in February. No club nights 1 January or December. Latest details on the club website and by email to members.

CCCV COMMITTEE MEETINGS

Meetings are held monthly in locations decided each month.

CLUB BANKING DETAILS FOR SUBSCRIPTIONS AND PAYMENTS

BANK: Bendigo Bank - BSB: 633 000—ACCOUNT: 120 127 907

INVITATIONS

BMC Leyland Car Club invitation to the Battle of Waterloo - 28th June 2023

The BMC Leyland Car Club has extended an invitation to CCCV and CCOCA to meet with them for a drive and picnic lunch. Obviously by calling the event the Battle of Waterloo (and meeting up in Wellington Road!) these Anglophiles are trying to make a point, but we sure that if plenty of our clearly superior French cars turn up for the event we will be able to reverse history. Full details for this event are on the Club's website and page 6 of this newsletter.



Kay Belcourt doing the Motokharma run by driving the Bumblebee at Citin in South Australia.



On the strength of the March pub night, for the April meeting we again decamped from the clubrooms. This time to the Elsternwick Hotel for a more casual get together. This month we doubled the attendance and even had to ask for an additional table to be added! As well as the usual suspects It was nice to see some new faces and a few faces we haven't seen for a while.

One new member made the trip down from Maldon to join us and show off her recently acquired 2CV van. John Parson's was recently quoted saying our club is about good company, good food and good wine and I'd say last Thursday's meeting met that brief.

The next club night will be in the clubrooms, and we are lining up a guest speaker for the evening.

At the recent committee meeting we dispensed with the usual formalities and had a long discussion about the future direction of the club and how to future-proof it somewhat. The good news is that membership is steadily increasing, and we now have around 300 members. The club coffers are healthy as well so we are going to be around for a while yet. Lots of great ideas were thrown around with a focus on engaging younger members (yes we do have some) and partners in club events. The trick is finding a balance between the technical and social sides of the club. To that end more tech days are being organized for later this year and even the possibility of a shed crawl. If you're interested in showing off a restoration in progress let us know. We will see how the next pub night goes but it looks like they are proving popular enough to become a mainstay on the calendar. We'll try and mix it up a bit by moving them around the city, venue suggestions are welcome. There is even the possibility of a trip to Philip Island for a blast round the track.

It would be great to hear from some of you about why you joined the club. As far as the committee goes, all positions are up for grabs at the next AGM in November. If you're interested in joining the committee and shaping the club's direction now is the time to start thinking about it. Reach out to me at the president's email address or come grab me at a club event to have a chat about what position you're interested in. There are the usual President, Secretary etc. positions as well as general committee members so there is a role for everyone.

Nothing is set in stone and the committee is very flexible about changing how things are done.

Michael Faulks.
President.

FRONT COVER

CCCV & CCOCA Concours held at Rippon Lea.

Image: Dave Rogers.

BACK COVER

Ian Downie looking outside from within Rippon Lea during the CCCV & CCOCA Concours.

Image: Dave Rogers.

*The Newsletter proudly printed by Snap Printing
Factory 2, 8 Enterprise Avenue, Berwick.
berwick@snap.com.au*

DISCLAIMER

This newsletter may contain articles with suggestions and advice for maintaining and modifying your car. It is your responsibility to ensure that any modifications or maintenance carried out on your vehicle conforms to all applicable safety and design laws and regulations and any stipulation made to your insurance company. The editors, authors, CCCV Inc. Committee and Members decline any responsibility for any transactions begun through contacts made in the CCCV.

CCCV NEWSLETTER COPY DEADLINE: Sunday night, after the 2nd Wednesday of the month.



NOTICE BOARD



Club password for the month: This has now been deleted and by simply logging on to the CCCV website: www.Citcarclubvic.org.au you can view all sections including the newsletter without having to remember a monthly password.

New Members . CCCV welcomes the new members to our family: Tim Lee, Don & Jan Willing, Andrew & Leanne Shouksmith. We trust you will enjoy your membership and we look forward to seeing you at club meetings and monthly outings.

LHM OIL for members: The price of LHM oil is now \$18.00 per litre as at 10/11/21 (see p/35 for your closest rep) Unfortunately we have had to increase this charge because of rising purchase cost to the club. It is still well below retail price.

LDS OIL available at club rooms on club nights only at \$25.00 per litre.

Events Calendar

Draft Activities Program

2023

NOTE: Club nights are held bi-monthly in our club rooms at 8/41 Norcal Road Nunawading, Mel 48/G11 at 8pm **ON THE THIRD THURSDAY IN THE MONTH, starting in February. No club nights in January or December. Latest details on the club website and by email to members.**

Club nights now start at 7.30pm.

Monthly 1st- Chit-Chat Tuesday Chit-Chat Tuesdays will be at Laneway Espresso Café – next door to Dromana Hotel – from 10 am onwards. This is a low-key “DIY” event for likeminded Citroen owners to meet and chat. Contact: Warwick Spinaze 0407 016 719 **CCOCA & CCCV event for coffee & chat.**

Monthly BOY’S DAY OUT-Port Arlington Golf Club-
WHEN: The fourth Thursday each month and the third Thursday in December (See p/7) 10.30 am for 11.30 departure & leaving from 1/29 Everist Rd, Ocean Grove Industrial Estate. **CCOCA & CCCV event for coffee & chat.**

Jun	15	Club night- <u>Pizza meal in clubrooms</u> at 7.30pm PARTNERS WELCOME
	18	Battle of Waterloo CCCV-CCOCA & BMC Car Club
Jul	8-9	Bastille Day—Queen Victoria Market’s Sheds C and D
	16	Bastille Day lunch CCCV-CCOCA
	20	Movie night—venue TBA
Aug	17	Speaker on Cylinder H-ds in Club Rooms
Sep	21	Pub meal
	24	DS Owners Tech Day Peter Moloney's Workshop
Oct	19	Club night—AGM
	22	French Car Festival –Patterson Reserve.
Nov		Run—CJ Dennis gardens TBA

2024

Mar 22-25 **CITIN RELOCATED TO DEVONPORT TASMANIA**
<https://citcarclubvic.org.au/cit-in-2024/>

Re- location of Cit-In 2024 to Devonport North West Tasmania. As you would all be aware, we recently presented the 2024 Tasmanian Cit-In event at Murray Bridge when the event was to be held at St Helens on the East Coast of Tasmania from the 22nd – 25 March 2024. Fortunately, we have been able to secure a new location at Devonport on the Tasmanian North West Coast and have booked the recently opened luxury Accor Novotel, situated on the banks of the scenic Mersey River opposite the East Devonport Spirit Ferry terminal. The previously advised dates of 22nd -25th of March 2024 will still apply so your members will not need to change your Spirit of Tasmania bookings.

CCCV Club Advice Line

Traction Avant	Ted Cross	9819 2208	SM	Lee Sholte	0404 150 038
2CV	Dave Rogers	0422229484	Xantia/Xsara	John Wyers	9787 6280
AX/Berlingo	Kirk Kirkcaldy	9363 2464	XM & modern models	Salman Chaudhry	0410 040 505
GS/GSA	Andrew Smith	9755 2439		Don Scutt	9807 8999
ID/DS	Contact CCCV		C2/C3	John Fedorko	0438 597384
BX	John Wyers	9787 6280	C6		
CX/C5	Graeme McDonald	0409 134 836			

Forthcoming Club Events

June 15th Thursday

Club night

Norcal Road clubrooms

THEMED MEAL



July 8th-9th

Free event, prices may apply to some of the ticketed program. Swap your beanie for a beret and come down to the iconic Queen Victoria Market's Sheds C & D this Saturday 8th and Sunday 9th July for the annual Bastille Day French Festival. Everyone's favourite celebration of all things French in Melbourne is back in 2023 with our most authentic feel yet in this new venue.



The Bastille Day French Festival of Melbourne will transport you to a classic wintry French town square and mark the start of the celebrations in the lead up to the French National Day.

A winter market packed with local French-Australian businesses, mouth-watering French cuisine, dazzling artists and performers, a ticketed program filled with Les Lumières talks, Walking Tours and masterclasses, right in the heart of the city! All with the delicious scent of croissants floating through the air. We will also have our Online Program in full swing so if you can't join us in person, join us online for a range of live crosses to France, in conversations, musical delights and more! Join us in person or online, as the joie de vivre returns this July.

À bientôt au Festival !

July 16th

CCCV - CCOCA

Churchill-Waverley Golf and Bowls Club - Rowville site

82 Bergins Road, Rowville Victoria 3178

ANNUAL BASTILLE DAY LUNCH



Booking form
details on page 7

Battle of Waterloo

The BMC Leyland Car Club have invited CCOCA and CCCV to join them for a picnic lunch and get together at Cardinia Lake.

To celebrate the 208th anniversary of the Battle of Waterloo which was fought on Sunday 18th June 1815



EVENT: Battle of Waterloo

WHEN: Sunday 18 June

MEET: Stud Park Shopping Centre – Stud Rd, Rowville

TIME: 9.00am for 9.30am Departure

ROUTE: Via a coffee break at Montague's Café, Lysterfield Lake, then onto Cardinia Lake Spillway car park before heading to:-

WHERE: Kangaroo Flat Picnic Area, Cardinia Reservoir Access Road, where battle will commence

DEPARTURE: Departure will be via Wellington Road

RSVP: Paul Buck 0412 627 711

BRING: Everything for a picnic lunch (there are a couple of gazebos should it be inclement weather)

FURTHER INFO: Paul Buck



COME ALONG, ENJOY THE FESTIVITIES AND CELEBRATE AT THE

BASTILLE DAY

LUNCHEON 2023

**Churchill-Waverley Golf and Bowls Club
Rowville Site**

82 Bergins Road Rowville Victoria 3178

WHEN: Sunday 16 July
TIME: 12.00pm for 12.30pm
COST: \$40.00 per head
Two course meal
Subsidised by your Club
Drinks at your own expense
Please wear your name tag

RSVP: Friday 7 July 2023



REGISTRATION AND PAYMENT



<https://form.jotform.com/230973602085860>

<https://form.jotform.com/230973533203855>

FURTHER INFORMATION:

marg.towt@bigpond.com

2CV LOW OIL PRESSURE AND LIGHTS-ON BEEPERS

By Graeme Dennes

Background

The 2CV incorporates an oil pressure warning light which turns on whenever the engine oil pressure falls below a safe value. The warning light also turns on during engine startup.

The warning light is operated by an oil pressure switch. In normal engine operation, the oil pressure is sufficient to hold the switch open, which keeps the warning light turned off. Should the oil pressure drop below the safe value, the oil pressure switch closes and turns on the warning light to alert the driver that the engine has insufficient oil for safe operation and is potentially in a catastrophic situation. Oil loss can be due to a range of causes, such as a loose oil union fitting or faulty oil pipe, or from a faulty oil cooler or connection. An improperly fitted oil filter or rocker cover gasket can also result in oil loss. It can also be due to insufficient maintenance (failure to top up the oil) or through leaving the oil breather cap unlatched.

The principle: During the operation of the vehicle, if the oil pressure warning light turns on, the immediate safety of the engine relies upon the driver immediately recognising the warning light and turning off the engine!

The reality: Should the driver be giving full attention to the driving task (which we generally concede has merit!), the driver may fail to observe the illuminated oil warning light. A possible loss of engine power or engine noises or smells may be the next thing that seizes the driver's attention! \$\$Ouch!

The goal: The elapsed time between the illumination of the warning light and its recognition by the driver needs to be absolutely minimised for the safety of the engine.

Question: How can the driver's attention be immediately drawn to the warning light whenever it turns on?

Answer: By sounding an audible alarm.

Purpose of Article

This article describes the fitting of an audible warning beeper which is activated immediately the oil pressure warning light comes on. The driver can then quickly confirm the illumination of the warning light and stop the engine before harm is done!

It also describes the fitting of a second audible warning beeper which is activated whenever the ignition switch is turned off with the lights on. The beeper acts as a reminder to turn off the lights to prevent a flattened battery!

Circuit Diagram:

Figure 1 shows the circuit diagram. Beeper B1 is the low oil pressure warning beeper, and beeper B2 is the lights-on warning beeper. Note the polarities of the beeper connections. Beeper B2 operates in conjunction with diode D1. Note the three points labelled A, B and C, which connect to the vehicle's wiring. More follows.



Wiring Diagram:

Figure 2 shows the wiring diagram. Diode D1 has, as is conventional with all diodes, a coloured band at the cathode end of its body to indicate the cathode lead, and the cathode connects to the oil pressure switch, i.e., the banded end connects to the oil pressure switch. Don't reverse the diode connections. Again, note the three connection points A, B and C. These are the same points, respectively, as the points A, B and C shown in Figure 1, because Figures 1 and 2 are functionally identical.

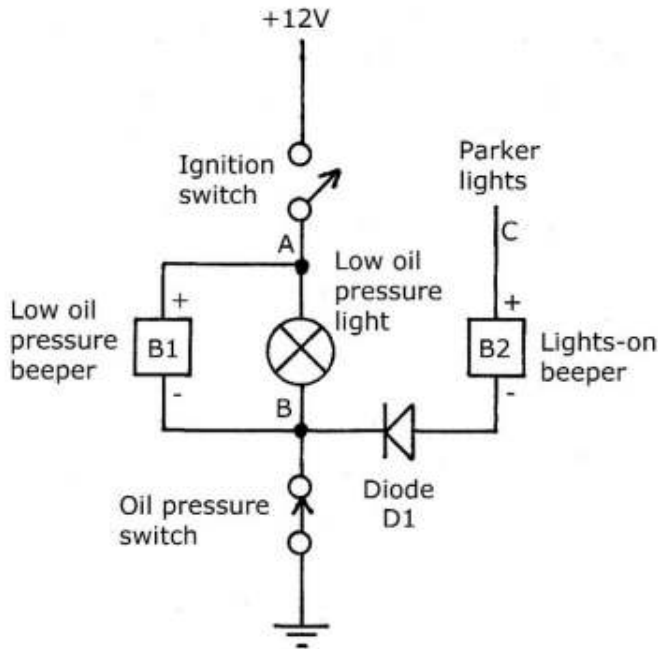

Figure 1: Circuit diagram

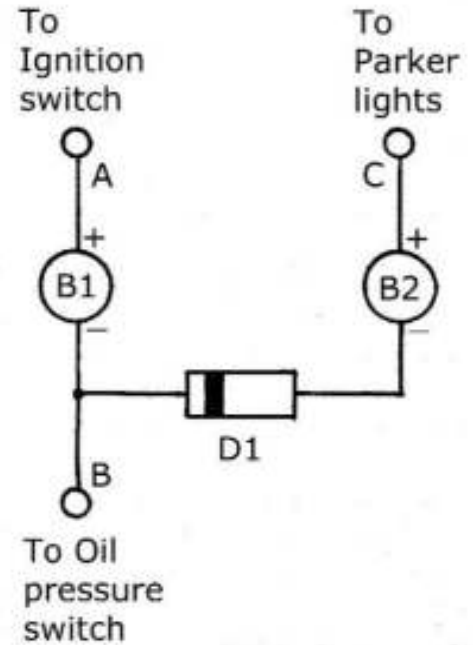

Figure 2: Wiring diagram

Figure 3 shows the 1N4004 diode used in this project. It is a 1 amp, 400 volt general purpose silicon diode. Note the coloured band on the left end which signifies the cathode end. The lead on the right is the anode lead, **which connects to beeper B2.**

Low oil pressure warning beeper:

From Figure 1, the low oil pressure warning beeper is implemented as a 12V beeper connected in parallel with the oil pressure warning light. In operation, whenever the oil pressure light is on, the beeper will sound. This includes during engine startup.

Lights-on warning beeper:

From Figure 1, the lights-on warning beeper is implemented as a 12V beeper wired with a series-connected diode. The positive wire from the beeper connects to the parker lights connection on the light switch, from which it receives +12V whenever the lights are on. (Here, parker lights refer to the two front parking lights, the two rear tail lights and the speedometer light, which are all operated together by the light switch whenever the lights are on.) The cathode (banded end) of the diode connects to the oil pressure switch. The anode of the diode connects to the negative wire of the beeper.

The lights-on beeper operates as follows. Consider the situation when the engine is switched off (the oil pressure switch is closed) and the lights are on. The positive wire on the beeper connects to +12V at the parker lights connection on the light switch, and the cathode of the diode connects to ground via the oil pressure switch.





Through the series connection of the diode and the beeper, the diode is forward-biased and conducts, operating the beeper and alerting the driver.

Now consider the situation when the engine is running (the oil pressure switch is open). The cathode of the diode connects to +12V from the ignition switch via the oil pressure warning light. This prevents the diode being forward-biased, regardless of the position of the light switch, so the diode does not conduct and the beeper does not operate.

Types of Warning Beepers:

There's different beepers available in the marketplace which differ in operating voltages, sound intensities and tones (constant tone, pulsing tone, rising tone, melodic tone, etc). This article requires beepers which operate at 12V DC, with a sound level which will be heard above the operating noises, oops, sorry, the purring tones, of the 2CV!

Mounting of parts:

The two beepers and the diode are assembled in a small plastic box with a removable lid. Mount the two beepers on the outside face of the bottom of the box, and mount the diode inside the box. All wiring connections and terminations are done inside the box. A tag strip inside the box is used to terminate the diode and all the wiring connections. More follows.

Connections from Plastic Box:

The plastic box will have three wires exiting it. The three wires connect to the vehicle wiring per Figure 2, and are (1) the wire to the switched 12V line from the ignition switch, labelled A, (2) the wire to the oil pressure switch at the oil pressure warning light, labelled B, and (3) the wire to the parker lights at the light switch, labelled C. Fit a rubber grommet in the small hole in the plastic box where the wires exit. The three connecting wires will need to be safely anchored inside the box to prevent them being unintentionally pulled from the box and damaging the wiring connections inside.

Vehicle Installation:

Figures 2 and 5 are identical electrically, and both are subsets of Figure 1. The three figures include the components B1, B2 and D1, and the wiring connection points A, B and C. These connection points connect to the same connection points, A, B and C, respectively, in the vehicle wiring diagram at Figure 6, using three lengths of insulated wire of different colours. More follows.

You will need to select a suitable, secure mounting location for the plastic box. It could be positioned behind the instrument panel or underneath the parcel shelf. The three wires from the box should be securely routed, supported and protected from physical movement and damage.

Installation Notes:

Because of the variety of different wiring installations used by Citroen over the 43 years of 2CV manufacture, it is not possible to provide a definitive procedure to connect the three wires from the plastic box to the vehicle's wiring. However, some points are essential, and also apply in general to vehicle electrical components and connections:

1. All wiring connections should be done with physical and electrical integrity in mind. Solder all connections.

- ←
2. All electrical connections and components should be insulated from each other, including all 12V wiring, all ground wiring, other components and all structural metalwork (ground).
 3. The diode and beepers need to be mounted in a manner which physically supports and protects them and their connecting wires from damage and stress, including electrical connections, and physically located and secured so they don't move or flex during vehicle operation.
 4. The diode is a small plastic encapsulated component which may be damaged if excessive tension is applied to the leads, so the diode leads should be safely anchored to mounting points with proper strain-relief applied.

Parts Required:

- o 2 x Beepers, B1 and B2: The Jaycar beeper No: AB3462 is suggested. This beeper is 22mm in diameter, 12mm high and is fitted with two mounting tabs. The red wire is the positive connection and the black wire is the negative connection. This beeper is shown at Figure 4.



Figure4: Jaycar beeper AB3462

- o 1 x Silicon diode, D1: Type 1N4004, 1A, 400V.
- o Small plastic box with removable cover to mount the two beepers and the diode, and to terminate the three connecting wires.
- o Rubber gromet to protect the three wires where exiting the plastic box.
- o Five-terminal tag strip with central mounting foot. More follows.
- o Three lengths of connecting wire of different colours.

Note: All parts are available from Jaycar. Other suppliers may provide equivalent parts.

Tag Strip Wiring Connections:

Figure 5 shows the wiring connections inside the plastic box. The 5-terminal tag strip is mounted inside the box and is used for soldering the beepers, the diode and the three external connecting wires at points A, B and C. The unused centre terminal has a mounting foot for mounting the tag strip to the inside face of the plastic box using a small screw, washer and nut.

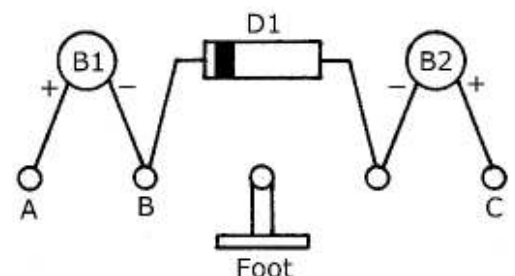

Figure 5: Tag strip wiring

B1 is the low oil pressure beeper and B2 is the lights-on beeper. The beepers show the plus and minus polarity requirements. For the suggested beepers, the + wire is coloured red and the – wire is coloured black. D1 is the diode, with its cathode (banded) end connected to B1 and its anode end connected to B2. The Figure 5 connection points A, B and C are the same, respectively, as those in Figures 1 and 2.

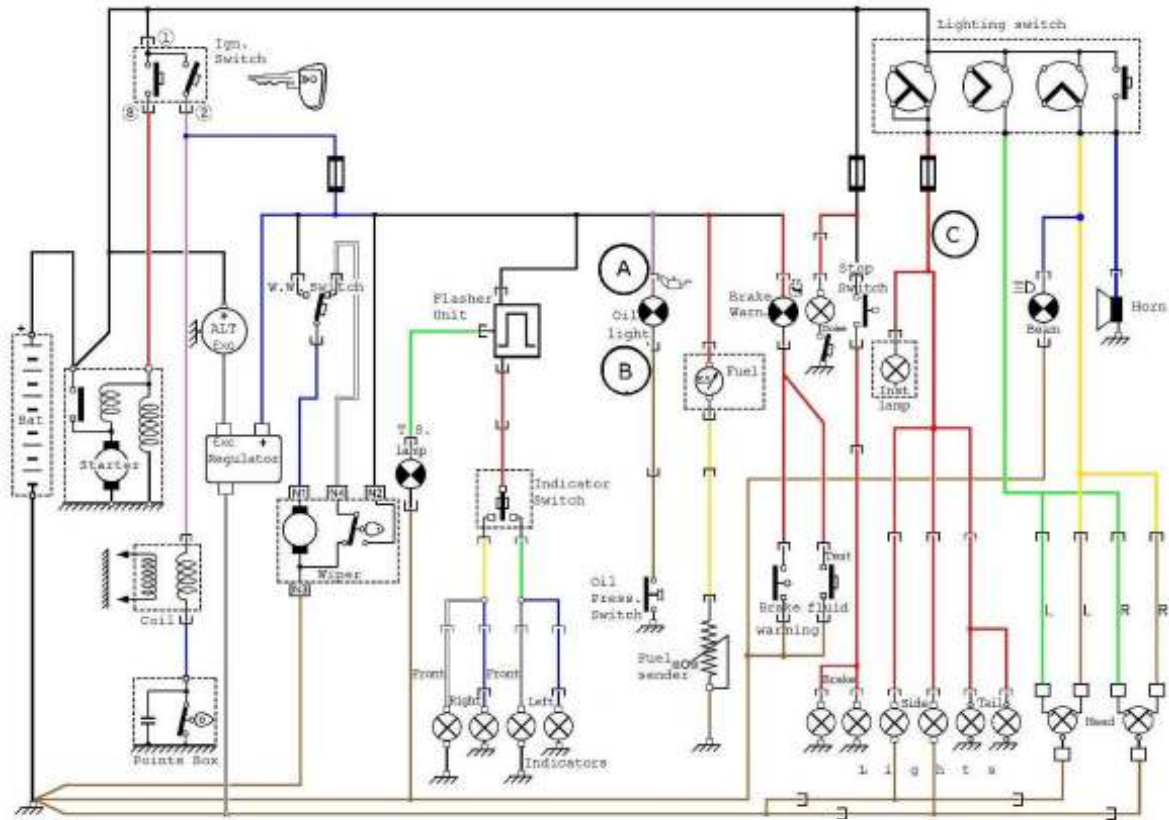

Figure 6 – 2CV 1981 wiring diagram (author unknown)

2CV 1981 Wiring Diagram:

Figure 6 shows the wiring diagram for the 1981 2CV, modified by the addition of three circles with the inscribed letters A, B and C. The three wires from the plastic box connect to these three connection points. The wire adjacent to the “A” circle is the switched 12V line from the ignition switch. The wire adjacent to the “B” circle is the wire connecting the oil pressure switch to the oil pressure warning light. The wire adjacent to the “C” circle is the parker lights connection at the light switch.

Complete Electrical Diagram: (What took you so long??!)

Figure 7 below shows the complete electrical diagram which provides the 2CV with a low oil pressure warning beeper and a lights-on warning beeper. Figure 7 is a composite of Figures 5 and 6, and shows Figure 5, the plastic box components, connected to Figure 6, the 2CV electrical system, via the three connecting wires linking the points A, B and C in each figure.

Easiest Wiring?

To simplify the task of connecting the plastic box wires A and B to the 2CV’s electrical wiring, then referring to Figure 7, connect the wire A from the plastic box to the upper connection terminal of the oil warning light holder and connect the wire B from the plastic box to the lower connection terminal of the oil warning light holder. Connecting the A and B wires directly to the oil warning light holder will be somewhat easier than other connection options. Ensure the wire connections are the correct way round, i.e., wire A connects to the 12V line and wire B connects to the oil pressure switch line.

Lights-On Beeper Option:

If you should find there is sometimes a need to have the lights on when the engine is not running, then to disable the (annoying!) beeper, a switch could be wired in series with it so it may be turned off when necessary. Remember to turn it back on afterwards...!

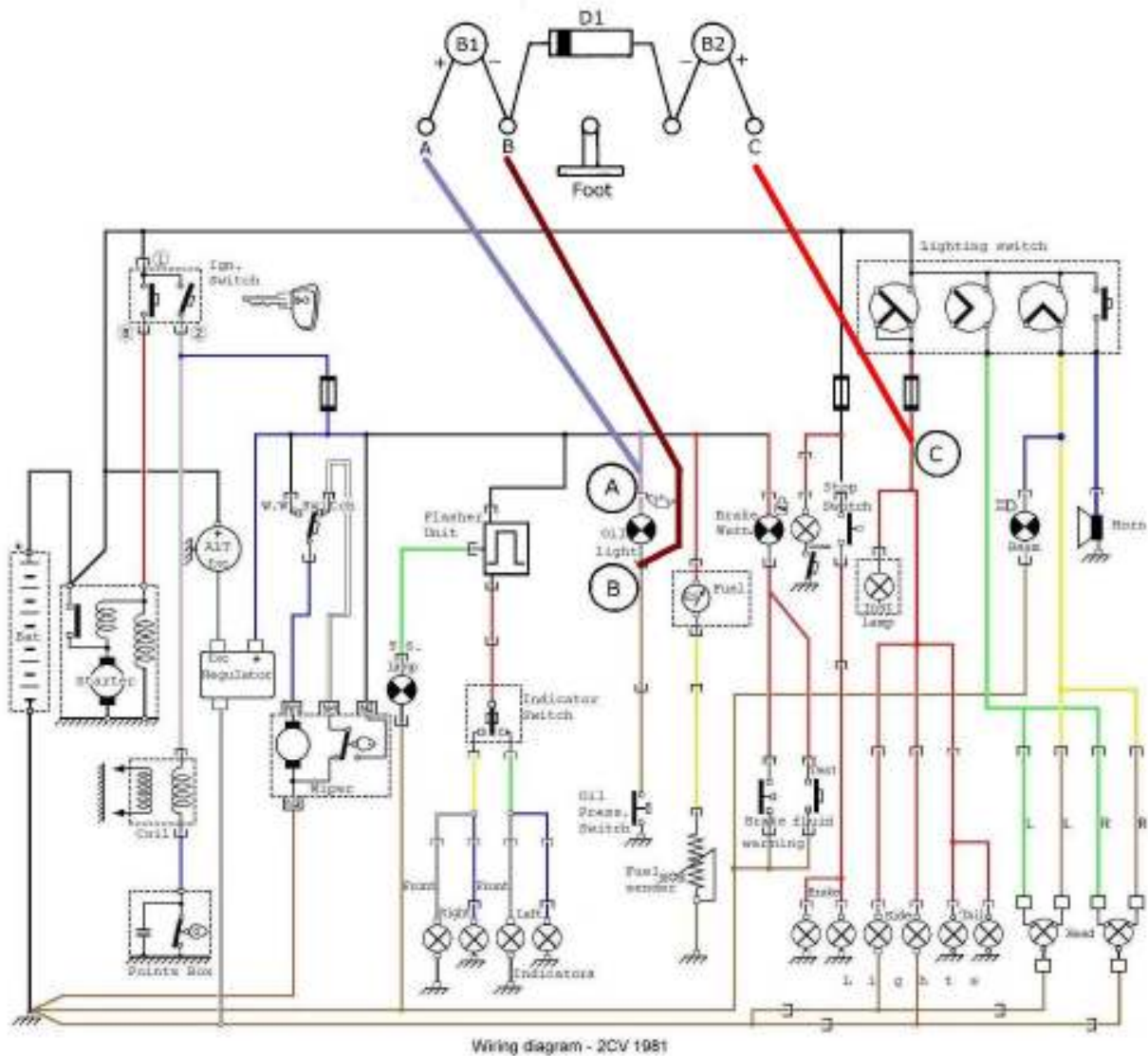

Figure 7 2CV Electrical Diagram with the Warning Beepers Added

FINAL STATEMENT

My grateful appreciation and acknowledgement is given to the web sites from which photos/images/diagrams have been sourced.

The article may be updated in the future and assigned a new revision number. Before using the information in this article, ensure the most recent revision is being used.

Should you have questions about the information in this article, if you find errors or have suggestions for improvement, or if you wish to re-publish this article in your club magazine, please contact the author at: gdenes@gmail.com

Copyright © Graeme Dennes 2023

REVISION

Since publication this article has been revised with minor changes and additions.

For the latest version go to:

<https://citcarclubvic.org.au/wp-content/uploads/2023/05/2CV-LOW-OIL-PRESSURE-BEEPER-AND-LIGHTS-ON-BEEPER-REVISION-1.pdf>

We had 23 combined club cars plus a dealer car so 24 in total, including a CCOCA member who was visiting from Tasmania and his car, a maroon Traction won the pre-1960 prize. The first time an interstate car has won a category at a Victorian concours.

CCCV—CCOC

202

WINNERS

Pre 1960	John Alwood (Tasmania)	L15
DS. ID. GS.	Leigh Schultz	DS 23
A series	Colin Bates	Ami 8
Late models	Andrew Switala	C6
Most popular	Simon Marshal	SM



Leigh Schultz DS23



Pre 1960



Colin Bates A series Ami 8

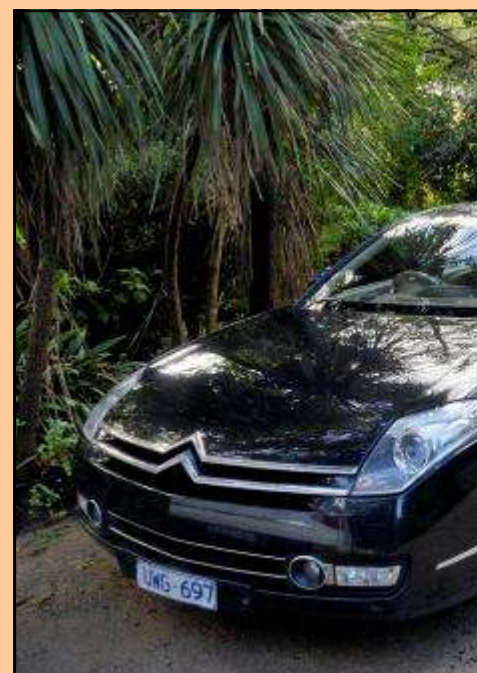

Andrew Switala

A CONCOURS

23



John Alwood (Tasmania) L15



Rippon Lea Estate is a heritage-listed historic house and gardens located in Elsternwick, Melbourne, Victoria, Australia. It is in the care of the National Trust of Australia. It was added to the Australian National Heritage List on 11 August 2006

The house was completed in 1868. It was built for Frederick Sargood. Sargood made his money selling soft-goods on the goldfields. The house is named after his mother's maiden-name, Rippon. Lea is an English word for meadow. The property was a large, self-sufficient farm, about twice the size it is now. The mansion was originally 15 rooms; it currently has 33 rooms. Sargood moved in with his first wife, Marian, and their 9 surviving children. There were 7 maids, a butler, 7 gardeners, a coachman and a groom.

Sargood was a typical man of the Victorian Age – visionary and practical. This resulted in an elaborate underground watering system and the house having its own electricity supply. Unusually for its time, the house had internal toilets. Sargood was a keen gardener who was particularly interested in orchids and ferns. A large number of plants were imported.



a C6



Simon Marshal SM

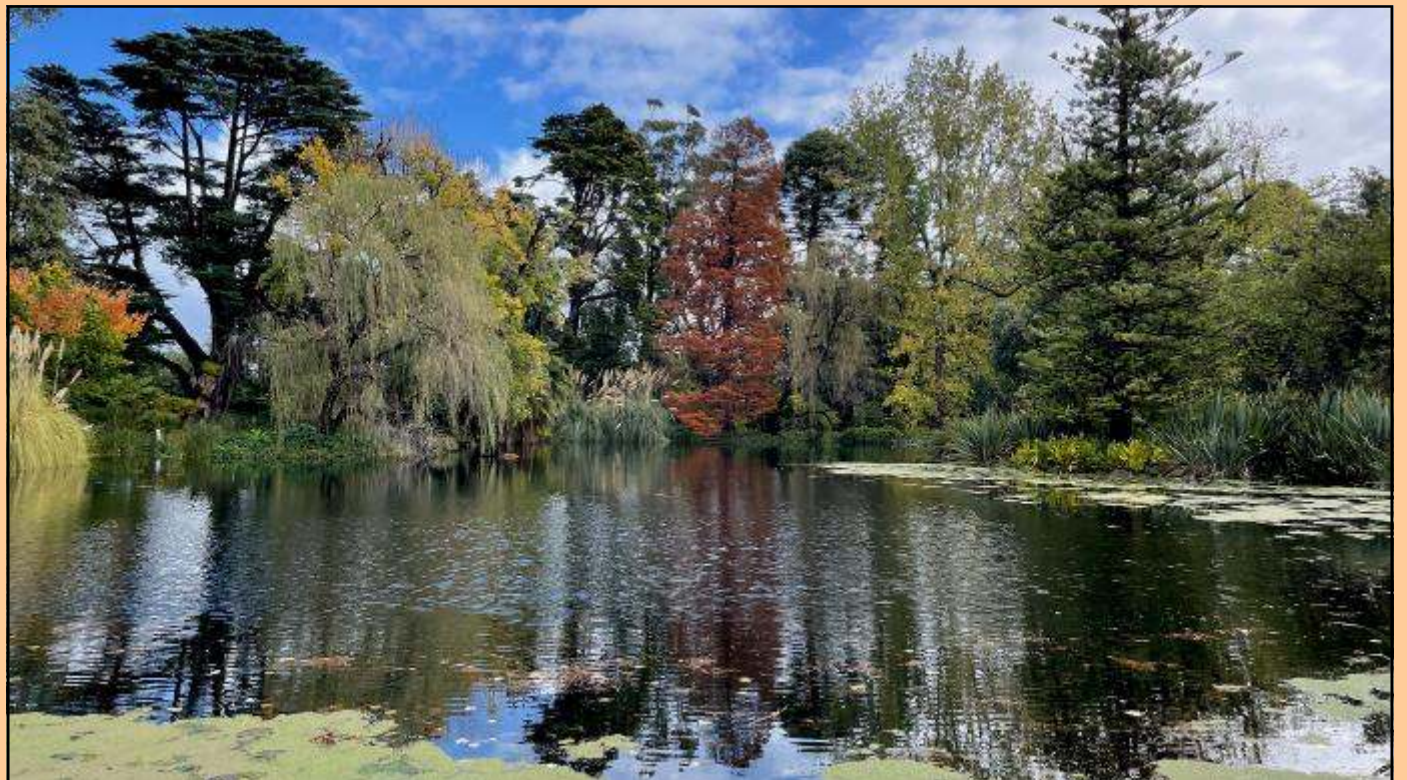





Sales and Wants

Free – Citroën BX and Xantia rolling bodies

06/23

Member Robert Fatchen has two rolling body Citroëns which he is happy to give away to any CCCV member, or members, who want them. Robert comments that he bought them as project cars, but now realises that he is never going to do anything with them.

The first vehicle is an auto BX. Robert comments that this car had an attempted weld to the dash. Interior is good. Body is rusted in the usual places.

The second vehicle is a Xantia which has no key. The previous owner had lost it, but suggested the vehicle was going. The previous owner had bought it for parts so some of the electric switches are missing. Robert says that he bought it for panels, but subsequently the Xantia he already owned was written off in an argument with a kangaroo.

Some photos of the vehicles follow.



The vehicles can be viewed at and collected from East Trentham. If not taken away the vehicles will be crushed.

If interested in either of these vehicles **call Robert on 0418 205 138**. Robert notes that he is often working out of mobile 'phone range so if no answer leave a message, or text him.



CITROEN CONCOURS 2023 Pages 14—18

I would like to express my appreciation to the following members who forwarded to me images and information about this year's Concours, as I was not able to attend it.

- Dave Rogers
- Peter Moloney
- Ian Downie
- Leigh Scholte

Editor.

List of Citroen DS parts for sale.

1. Air cleaner complete with filter
2. Air intake hose from bumper bar to cold air fan unit
3. Air intake hose from bumper bar to heater fan unit
4. Alternator 75 amps
5. Bonnet hinges
6. Bonnet closing pins.
7. Brake pads main
8. Parking brake pads (& retaining spring clips)
9. Brake shoes new
10. brake drums one pair.
11. Brake pedal rubbers plus clutch pedal rubbers
12. Bumper bar 3 pieces Front DS type
13. Bumper bar pre 1965 type complete
14. Bumper bar rear
15. Cylinder head DS 21 and DS 23
16. Carburator heater hose from coolant pump new both types
17. Carburator hose to air cleaner
18. Centre muffler
19. Citroen chevron on rear mudflaps
20. Cooling system hoses
21. Cold air fan and housing
22. Clutch cable
23. Distributor body
24. Distributor points
25. Distributor condenser
26. Distributor cap
27. Distributor rotor
28. Driving lights
29. Door glass and runners and winders
30. Door handles inside and out
31. Driving light globes (new)
32. Engine oil filter plus cover gasket
33. Exhaust pipe clamps
34. Flexible exhaust (new)
35. Front arms both sides with good bearings
36. Front spheres with removable damper valves
37. Front over riders
38. Front guards
39. Front doors
40. Front number plate panel
41. Front indicators
42. Front spheres with fixed valves
43. Front spheres with removable damper valves
44. Front suspension cylinder gators (new)
45. Front suspension cylinder with piston
46. Front valance &
47. Fuel pump mechanical
48. Fuel pump electric
49. Gearbox BVH type
50. Gearbox oil
51. Gear change handle housing rubber (new)
53. Headlight Headl Head light switch ID19
54. Headlight boxes complete with access door
55. Headlight glass
56. Headlight glass perspex covers on suction cups or velcro type
57. Heater control valve control late type
58. Heater radiator
59. Heater fan housing
60. Heater hose rubber
61. Heater hose metal with
62. Height Correctors (refurbish)
63. Hubcaps all types (early DS, large & small ones
64. Heater hose connection to metal hose
65. Heated rear window glass sedan
66. Instrument cluster early type and 3 dials type.
67. Main accumulator (refurbish)
68. Main Regulator (refurbish)
69. Main headlight bar
70. Power steering with new seal kit and rechrome piston and valves and dust gaitor
71. Piston and housing for hydraulic gearbox
72. Radiator aluminium & vinyl shroud
73. Radiator early type no expansion tank
74. Radiator cross member aluminium schroud
75. Rear indicator trumpets
76. Rear doors
77. Rear indicators lamp and amber lenses
78. Rear window glass sedan
79. Rear window glass safari Perspex type
80. Rear guards (sedan)
81. Rear suspension bump stop (new)
82. Rear suspension gators (new)
83. Rear suspension ball bearing (new)
84. Rear suspension ball bearing grease cups.
85. rear Spheres split types
86. Rear Spheres valves
87. Regulator electric for Alternator
88. Regulator hydraulic
89. Rubber over-riders front
90. Spare rim with tyre.
91. Spare wheel cover
92. Sump plug gasket
93. Stainless steel trims (PALLAS) inner and outer
94. Starter motor new
95. Tail lights
96. Thermostat
97. Turning headlight parts.
98. Turning headlight cables
99. Valance
100. Water pump housing (new)
101. Water pump body with pulley (Refurbished)
102. Wheel rims 5 studs
103. Window winders (front & rear)

All prices negotiable

Contact Rob

Mob: 0439 798 079.

For sale – 2012 Citroën C5 touring wagon

04/23

Member Richard Ward has for sale:

- 2012 Citroën C5 touring wagon.
- VIN—VF7RWRHHAAL510301.
- second owner.
- service history available.
- everything in excellent condition.
- odometer — 116,500 km.
- registered until September 2023
- two keys
- asking price—\$10,500.

May be viewed at Fingal or South Melbourne.

If interested call or text Richard on 0417 316 060.



For sale – 2013 Citroën C5 Exclusive Sedan

12/2022

Michael Pearce has a 2013 C5 Exclusive sedan for sale. His description of the vehicle is as follows:

- VIN: VF7RD5FVADL501719
- 77,000 km
- 4 cylinder turbo-charged petrol engine, 6 speed automatic transmission
- sun-roof and leather upholstery
- very good condition and drives well
- small damage to rear passenger arm-rest
- location – South Melbourne
- asking price \$15,650 ONO

If you are interested in this vehicle contact Michael on 0411 265 409



For Sale 2014 Citroën C5

Exclusive sedan

03/23

- 2litre turbo diesel automatic for sale. Reg no. AAZ 414
- Vin no. VF7RDRHHADL520765
- Engine no. 10DYZD4055701
- I'm its only owner and I purchased it new from Bayford Citroen in January 2014.
- Colour is black with black leather interior, sun roof, air suspension, tinted windows, satnav, towbar and 19" Adriatique factory alloys, new Continental tyres, windscreen and battery and 11 months registration.
- Travelled 123,000 kms with fully stamped service book from Paris Motors since new and all maintenance invoices on file.
- A strong reliable car in good condition with RWC.
- Asking price \$12,500

Location Camberwell

If interested, please 'phone John Hutchins on 0408 344 866.

FREE

05/23

Chris Wilson, not a member of CCCV, has a pair of near new roof racks to fit a BX, which he has no use for and will give to any CCCV member who wants them.

The roof racks are located in Montmorency and if you would like to have them call Chris on:

0407 541 390, or e-mail him at:

wilwis@bigpond.com.

New 2CV Rocker Cover Gaskets:

For those 2CV owners who may be about to replace the rocker cover gaskets, consider using the new soft pliable rubber gaskets from Burton Car Parts. When compared to the standard gaskets, the new gaskets are much easier to remove, much easier to clean and much easier to fit. They can be reused multiple times and do not require adhesive. The gaskets have Burton part number A1.5319.

See the short YouTube video at [Burton 2CV Parts - Rocker Cover Gasket 2CV](#) comparing the standard gasket and the new gasket.

Graeme Dennes

04/23

PARIS APARTMENT

Apartment in Paris available to rent for CCCV members, sleeps up to 6 people.

Chic, sunny, renovated.

Located on the 4th floor of a secure residential Hausmannian building.

Comprising 2 bedrooms, each with a queen sized bed, plus two separate single beds in the living room. Elevator, entrance hall, fans, full kitchen, full living room, full separate bathroom, combo washer/dryer, separate walk-in shower. Beautifully decorated.

Famous rue Mouffetard, Place Monge market and two metro stations all 100m away.

Melbourne owners, CCCV members.

www.maisondelaclef.com.au

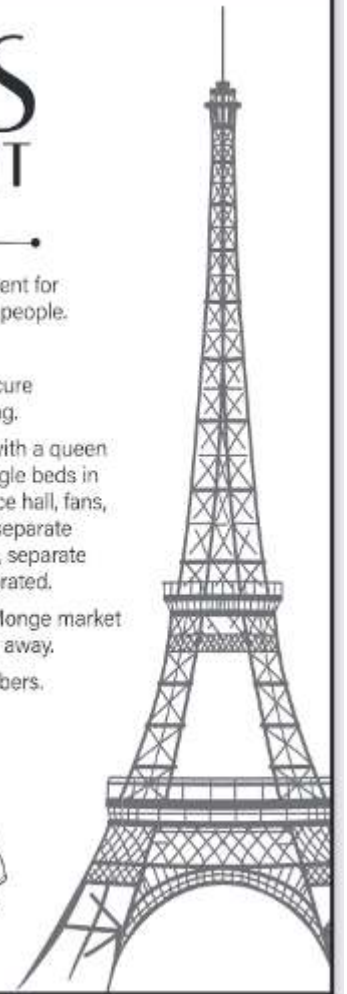

Wanted

03/23

Marchal reflector as shown in the picture as well as four springs as illustrated.

I have shown the type of Marchal light that is relevant for these fittings.

Ring: Rod Gleeson and mobile number is 0418 359 662.

I know these parts are rare but a member may have spare parts squirreled away.



Sales and Wants

FOR SALE 2013 Citroen C5 "Tourer" Station Wagon Exclusive.

2/23

HD i turbo diesel 6 speed auto, 80,000kms, one owner. Vin no VF7RWRHHADL512648

Fully serviced by Rex Gorell Citroen Geelong Vic. This vehicle is in immaculate showroom condition, metallic silver with grey leather interior. Hydropneumatic 111+ suspension with auto height adjustment to suit road conditions. 19 inch, 16mm offset alloy wheels, no spoke scrapes. "Goodyear Eagle" Sport Tyres.

\$22,500.00 or near offer.

Please ring Barry Oliver 0352431752 or 0412646981.

CLUB MEMBERS NOTE: SPHERE RE-GASSING SERVICE NOW AVAILABLE FOR \$25-00

Note: removal and fitting of spheres is not included.

This service is strictly CCCV members only

CONTACT WOLFGANG SIEM ON 0425 872
082

Wanted Citroen DS21 1967 to 1969 Dash 06/23

I am after a Citroen DS21 dash 1967 to 69.

Actually not sure of the year but have included a photo.

David Sutcliffe

Contact me on 0448913004.



Pleiades

Automotive Hydraulics (Australia) Pty Ltd

A.C.N. 087 262 388

« THE CITROËN HYDRAULICS SPECIALISTS »

Over 35 years experience

We recondition: - Steering racks, Pumps, Spheres, CX steering control units,
Gas struts, Height correctors, BX strut etc.

We supply (Ex UK):- Corrosion resistant pipe, Flaring tools, Fittings, Seals
& a wide range of Citroën Spares

IF YOU HAVE ANY CONCERNS BUT ARE UNSURE OF THE CAUSE, PLEASE RING FOR ADVICE



AUSTRALIA: -

PO Box 834 Childers Qld 4660
Phone/Fax: (07) 4126 2502
Mobile: 0427161132
email: pleiadesauto@pacific.net.au

UK:-

12a Brookside
Sawtry
Cambs, PE28 5SB UK
Tel/Fax: (001144) 1487 831 239
email: pleiades.sawtry@gmail.com
www.pleiades.uk.com

For sale – 1986 Citroën 2CV6 Special

05/23

Frank Zantvoort (not a CCCV member) has for sale a:

- 1986 Citroën 2CV6 Special;
- VIN – VF7AZKA00KA184843;
- Odometer reading – 41,813 miles;
- Registered to July 2023;
- Road Worthy Certificate – to be sold without a RWC, but this is negotiable;
- Location – Moorooduc;
- Asking price – \$25,000.

Frank comments “I bought this car in 2014 with 41,310 miles showing on the odometer so very little use, mainly display at a winery and the occasional memory lane spin, otherwise it only collected dust in our machinery shed. Recently bosed her down, put in a new battery and off she went. Generally in good condition as can be seen in the photographs following, some rust, good roof. Maintained by Paris Motors and some receipts for work done can be provided. Will come with original Owner’s Manual and Haynes Workshop Manual.”

If interested call or text Frank on 0408 532 564, or e-mail him at frank.zantvoort@gmail.com



Full details on CCCV club website.



For Sale – tyres and rims for Citroen DS

02/ 2023

4x tyres and rims for a DS – see detail in photographs following.

Asking price \$35.00 each/\$140.00 for the four.

If interested contact Graeme Thompson on mobile 0412 823 119, or e-mail gpthompson@vicbar.com.au



Wanted to buy C3 Pluriel

06/23

Club member John Froehlich is seeking to purchase a C3 Pluriel. He is looking for one in good condition, registered and roadworthy and, preferably, located in Victoria.

If you can assist John with a purchase please contact him by email at froehlichjohn42@gmail.com or 'phone 0490 004 342.

AUTO TOOLS AVAILABLE TO MEMBERS

USE ONE of the many tools that the club has available for members to borrow.

A full detailed list of what is available is listed on the Club’s website.

Wanted.

11/22

Can anybody help our Tasmanian member, Bauke Meijer who is looking for a right hand side (driver's) mudguard in good rust free condition for a third front DS? If you can assist please contact Bauke by text on 0408 781 254 or email at mothers-worry79@gmail.com



BEAUTY IS IN THE EYE OF THE BEHOLDER

For almost 30 years Shannons have been committed to providing tailored insurance products for the motoring enthusiast. We understand the passion and the sheer emotional attachment motoring enthusiasts have for their special vehicle - even Goggomobils.

Today, Shannons is the insurer of choice for motoring enthusiasts across Australia, providing innovative and flexible insurance options, like a **10% Multi policy discount** when you add a home and/or contents policy to your existing Shannons car or bike policy. You can even pay your premium monthly at no additional cost.

So call Shannons for a    quote on 13 46 46.



SHARE THE PASSION

INSURANCE FOR MOTORING ENTHUSIASTS | CALL 13 46 46 FOR A QUOTE | SHANNONS.COM.AU

Shannons Pty Limited ABN 91 099 692 636 is an authorised representative of ANI Limited ABN 48 005 297 807, the product issuer. Read the Product Disclosure Statement before buying this insurance. Contact us for a copy.

Darebin Tyre and Service Centre
Incorporating
Cars of France

170 GRANGE Rd. FAIRFIELD

Ph: 03 9499 7522

03 9499 2478

www.carsoffrance.com.au



- **CITROËN Service**
- **Full & Part restoration**
- **Proxia & Sagem Diagnostic Equipment**
- **Sphere regas, change over starter motors**
- **Change over alternators & hydraulic components**
- **Spare Parts New & Used**

TYREPLUS EASTLAND

crn BOND & NEW STREET RINGWOOD 3134

PHONE: 9879 8487



PROPRIETOR
STEFFAN ROSIER

*Please check for current
stock and prices.*



**ALSO NOW
IN SYDNEY**

EUROPEAN AUTO IMPORTS

Parts for Peugeot, Renault, Citroën and Alfa Romeo

Carrying the largest stock of parts for these marques in Australia.

Club discount on production of current membership card. Mail order.

321 Middleborough Rd
Box Hill VIC 3128
Ph: (03) 9899 6683
Fax: (03) 9890 2856

Unit 3/10 Pioneer Ave
Thornleigh NSW 2120
Ph: (02) 9481 8400
Fax: (02) 9484 1900

eai@eai.net.au

www.eai.net.au

LHM SALES (Strictly Members Only)

ABN 74557610508

\$18.00 for 1000 ml container

Cheque, money order or EFT (payable to CCCV Inc.)

Note: Purchasers must receive a receipt.

Mentone	Stephen Maloney	0438 155 797
Western Suburbs	Ferdi Saliba	0409 384 977
Glen Iris	Colin Bates	9822 2864
Ringwood	Wolfgang Siem	0425 872 082
Somerville	John Parsons	5977 6115
Ashburton	Robert Belcourt	9885 4376
Shepparton	Rob Little	5823 1397
Warrnambool	Roger Wilkinson	5567 1037
Hurstbridge	Adelino de Silva	0419 886 480

Also available from club shop at club meetings.

